

**RECOMMENDED GOOD PRACTICE**  
**MATERIALS AND WELDING GUIDELINES**  
**FOR**  
**BLACK LIQUOR RECOVERY BOILERS**

**THE BLACK LIQUOR RECOVERY BOILER ADVISORY COMMITTEE**

April 2009

Table of Contents

**GENERAL DOCUMENT FORWARD..... 4**

**CHANGES ..... 5**

**GENERAL WELDING FORWARD (FOR SECTIONS 1 AND 2) ..... 6**

**SECTION 1 - WELDING BULLETINS ..... 9**

1.1 STRESS-ASSISTED CORROSION (SAC)..... 9

1.2 WELD REPAIR OF CRACKS IN WATER TUBES ..... 10

1.3 REPAIR OF PRESSURE BOUNDARY MATERIALS IN TUBES ..... 11

1.4 REPAIR OF CORROSION RESISTANT WELD OVERLAY APPLICATIONS ON TUBES ..... 11

1.5 REPAIR OF COMPOSITE MATERIALS ON TUBES..... 12

**SECTION 2 – WELDING GUIDELINES & PROCEDURES SECTION..... 14**

2.1 REPLACING HAND HOLE CAPS (WELD IN STYLE) ..... 14

    2.1.0 General ..... 14

    2.1.1 Hand Hole Cap Metallurgy..... 14

    2.1.2 Reusing hand hole caps: ..... 15

    2.1.3 General Good Practice Items: ..... 15

    2.1.4 Hand Hole Cap Removal Procedure..... 15

    2.1.5 Header Repair Procedure..... 16

    2.1.6 Hand Hole Cap Installation..... 16

    2.1.7 Handhole Caps Welding Guidelines – Removal Sequence & Header Repairs ..... 17

    2.1.8 Handhole Caps Welding Guidelines – Installation Sequence..... 18

    2.1.9 Detail of ½” Leg Fillet Weld ..... 20

    2.1.10 Weld Traveler..... 21

2.2 WELD REPAIR OF SMALL HOLES / CRACKS IN SUPERHEATER TUBES ..... 23

    2.2.1 Introduction ..... 23

    2.2.2 Evaluation..... 23

    2.2.3 Materials..... 24

    2.2.4 Procedure..... 24

    2.2.5 Acceptance ..... 24

    2.2.6 Reference ..... 25

2.3 REPAIR OF PRESSURE BOUNDARY MATERIALS IN TUBES ..... 26

    2.3.1 Introduction ..... 26

    2.3.2 Evaluation..... 26

    2.3.3 Materials Selection ..... 26

    2.3.4 Special Restrictions..... 26

    2.3.5 Welding..... 27

    2.3.6 Final Inspection ..... 27

    2.3.7 Documentation..... 27

    2.3.8 References..... 27

2.4 CORROSION RESISTANT WELD OVERLAY APPLICATIONS ON TUBES (FUTURE)..... 28

**SECTION 3 - MATERIALS ..... 29**

**GENERAL MATERIALS FORWARD ..... 29**

3.1 MATERIALS SURVEYS RESULTS: ..... 29

    3.1.1 Black Liquor Nozzle Wastage ..... 29

    3.1.2 Scope..... 29

    3.1.3 Corrosion Characteristics..... 29

    3.1.4 Causes of Corrosion ..... 29

3.1.5 Operating Issues .....	30
3.1.6 Mechanical Solutions.....	30
3.1.7 Materials Solutions .....	30
3.2 SMELT SPOUT MATERIALS SURVEY .....	31
3.2.1 Scope.....	31
3.2.2 Corrosion Characteristics.....	31
3.2.3 Causes of Corrosion .....	31
3.2.4 Materials Solution – Weld Metal Overlay.....	32
3.2.5 Materials Solutions – Miscellaneous Forms of Corrosion Protection.....	32
3.3 SMELT SPOUT STEAM SHATTER JET MATERIALS SURVEY.....	32
3.3.1 Scope.....	32
3.3.2 Corrosion Characteristics.....	33
3.3.3 Causes of Corrosion .....	33
3.3.4 Materials Solutions .....	33
3.4 MATERIALS – MISCELLANEOUS (FUTURE) .....	34
<b>SECTION 4 – TEMPORARY REPAIRS (Future) .....</b>	<b>35</b>
<b>SECTION 5 – REFERENCE SECTION.....</b>	<b>36</b>
5.1 OEM & SERVICE PROVIDERS .....	36
5.2 TECHNICAL SOURCES: .....	36
<b>APPENDIX A DOCUMENT REVISION HISTORY .....</b>	<b>37</b>

Table of Figures

FIGURE 1 – FLOW DIAGRAM FOR A SUCCESSFUL WELD REPAIR .....	8
--	---

## **GENERAL DOCUMENT FORWARD**

The BLRBAC Materials and Welding Subcommittee was formed to provide a center of expertise on recovery boiler materials and welding issues. The subcommittee's function is to promote safety and reliability of black liquor recovery boilers through development of materials and welding guidelines.

The following document provides information and guidance on matters relating to recovery boiler materials, welding and related issues. The term "materials" encompasses pressure and non-pressure part metals, paints and preservatives and refractories. The term "welding" encompasses precautions, preparation and procedures.

This document represents a compilation of materials applications and welding guidelines and practices drawn from experience during boiler manufacture, repair and maintenance. This document is not intended to be a "Standard" for repairs. Rather, it presents peer reviewed guidelines that can be considered for repairs and maintenance. The document sections will include the following elements:

- Problem Description
- Classification Indicator
- Details / Causes
- Areas Affected
- Recommended Inspection
- Recommended Actions
- Additional Information

The Subcommittee recognizes that these guidelines are only one small facet to the safe repair and maintenance of Black Liquor Recovery Boilers. No set of guidelines can cover all situations or specific problem areas encountered with individual boilers. This document may be helpful in the repair or upgrading of older boilers but it still should be used as a guide only. The responsibility of the final decision(s) and or action(s) taken in any and all cases lies with those in charge of recovery boiler maintenance and is beyond the intent and purpose of this document. It is not the intent of this Subcommittee to force major designs or operational changes to existing black liquor recovery boilers.

This document will be revised from time to time. Applicable codes and jurisdictional requirements shall take precedent over this document. This document is not intended to exclude alternative practices, procedures, codes and standards.

Additional information on recovery boiler welding maintenance and materials is available from TAPPI TIPS<sup>1</sup>, AF&PA Maintenance Manual<sup>2</sup> and other sources. The reader is encouraged to refer to these additional references and use the section in this manual's binder to collect relevant articles.

---

<sup>1</sup> TAPPI TIP's are available for a nominal fee from [www.tappi.org](http://www.tappi.org).

<sup>2</sup> The AF&PA Recovery Boiler Reference Manual Volume II Maintenance and Repair Analysis: Repair Guidelines and Practices

**CHANGES**

This is the first publication of this document.

## **GENERAL WELDING FORWARD (FOR SECTIONS 1 AND 2)**

Proper repairs to black liquor recovery boilers may be more critical than repairs to conventional power boilers. Improper or inadequate repairs may result in smelt/water explosion or extended loss of production.

An evaluation for permanent repairs should include a failure analysis using the failed component. However, it is understood that there are situations where it is not economical or feasible to obtain a sample to perform failure analysis.

Welded repairs should be based upon Jurisdictional requirements, National Board requirements, applicable standards, and mill requirements.

Several steps are required for successful weld repairs. The steps for a successful repair are to evaluate the need, determine the extent and type of repair, establish the repair plan, obtain proper inspector acceptance, review qualification requirements, implement repairs, and finalize repair acceptance criteria. Figure 1.1 provides the flow diagram for a successful weld repair.

### **Evaluating the need for repair**

Considerations to be used when evaluating boiler repairs should include:

- Can the serviceable life of the defective component be extended without a weld repair
- Should a sample be taken for failure analysis
- Is the repair considered temporary or permanent
- What are the consequences of the selected repair or alteration
  - What is the impact of the repair on safety and operation of the boiler
  - What is the impact of any modifications on future consideration

### **Determining the extent of the repairs**

A permanent repair may significantly impact repair schedule when a temporary repair would safely span the interval to the next scheduled outage. However a temporary repair may eliminate the ability to secure a sample for failure analysis. Availability of materials should be considered prior to making the repair. Evaluate the nearby components for collateral damage. Adjacent components may be damaged to gain access to the failed component.

### **Establishing the repair plan**

Items to consider in the repair plan are securing the boiler, cleaning the boiler, accessing the area, material requirements, safety of personnel, identifying personnel, equipment, and documentation requirements, communicate the field identification method, and duration of the repair process. Establish the pressure test requirements, including test pressure.

### **Obtaining proper inspector acceptance**

Identify the organization that will provide inspector acceptance. Identify the agency that will perform the inspection. Determine if this is a routine repair, a major repair or an alteration.

### **Reviewing qualification requirements**

Qualifications of the repair organization should be verified. Qualifications to be verified include:

- An approved Welding Procedure Specification(s) is(are) available
- Welding Procedure Specification(s) and welder(s) shall be qualified to ASME Section IX
- Material Lists meet code requirements and may require Mill Test Reports
- Nondestructive Examination process and technician qualifications
- Heat treatment procedure is available if required

### **Implementing repairs**

Implement the traveler. Identify someone to ensure established repair plans and procedures are followed. Establish inspection hold points.

### **Finalizing repair acceptance criteria**

Conduct the final closure inspection. Complete the final acceptance test procedure. Complete the final repair documentation. Identify follow-up activities that are required at the next scheduled outage if temporary repairs were made.

A simple graphical representation or flow chart of the repair process steps follows.

Figure 1 – Flow diagram for a successful weld repair

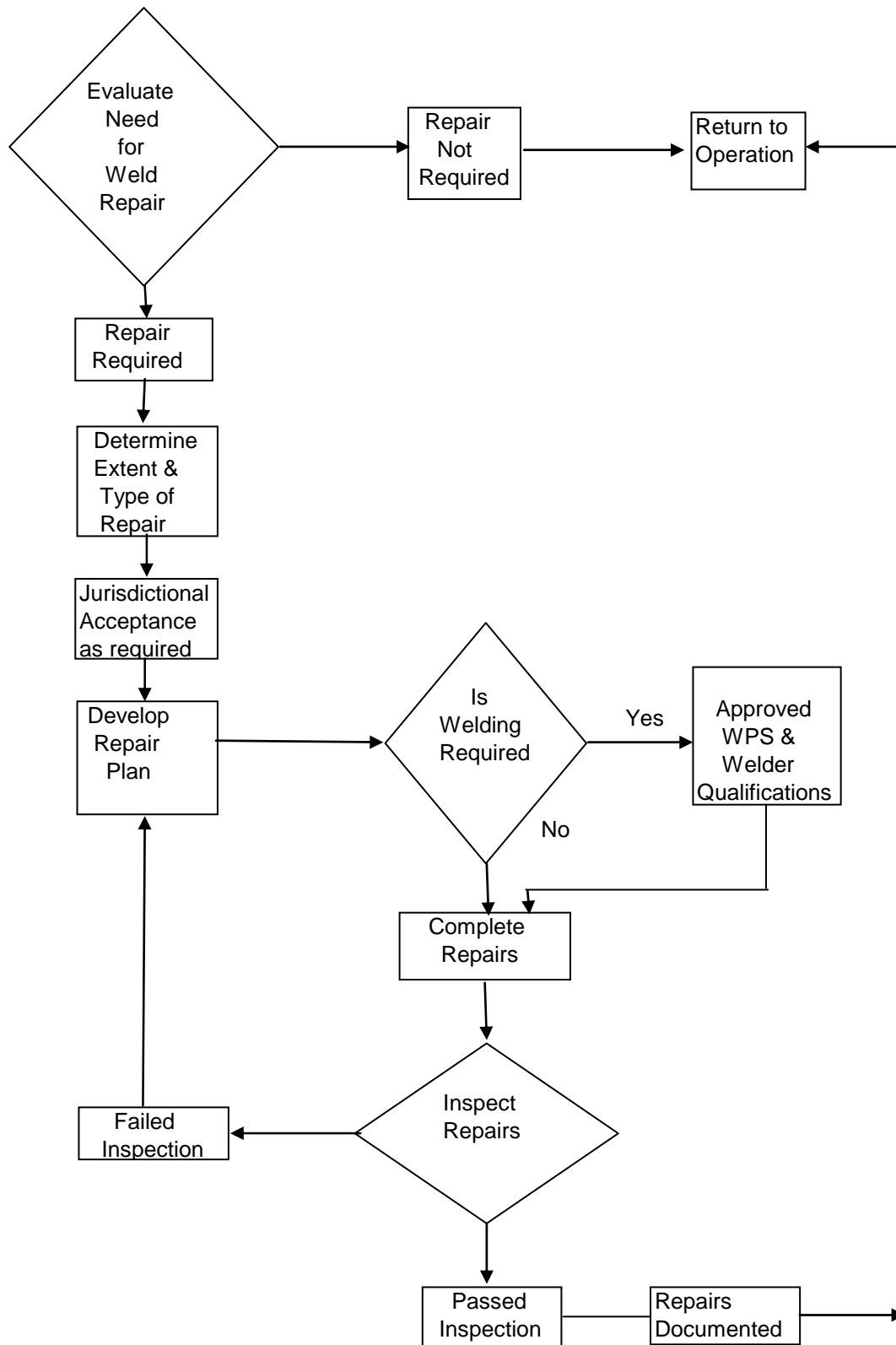

## **SECTION 1 - WELDING BULLETINS**

### **1.1 Stress-Assisted Corrosion (SAC)**

**Description:** Waterside Stress-Assisted Corrosion (SAC) is a common damage mechanism resulting in water leaks at weld attachments. SAC should be considered the likely damage mechanism whenever leaks occur in an area of weld attachments. The problem can occur in any of the water tubes of the boiler.

**Potential for Exposure:** Critical and Non-critical.

**Details / Causes:** The SAC mechanism is based on the premise that the highest stressed zone will selectively corrode in the boiler feedwater. Studies at the Electric Power Research Institute (EPRI) and elsewhere have shown that SAC occurs if the local strain on the internal surface of the tube exceeds a certain level such that the magnetite scale is fissured. This condition leads to corrosion of the steel at the bottom of the fissure, and also leaves the magnetite scale that eventually reforms at the fissure weaker, and therefore subject to repeated fracture. Repetitions of stress and/or changes in corrosivity of the feedwater cause crack-like crevices to grow.

**Boiler areas affected:** Areas of most concern are lower boiler regions where leaks are likely to introduce water into the furnace area: waterwalls at primary and secondary windbox scallop bar attachments, floor-to-sidewall seal bars and corner tubes. Other areas where SAC is common are nose arch seals, smelt box attachments, buckstay attachments and around port and manway openings.

**Recommended inspection:** Several nondestructive test methods (including radiographic testing, ultrasonic shear wave testing, acoustic emission testing, and remote visual inspection) have been used to inspect for the presence of SAC. No best method has been identified to inspect for SAC. Radiography, which has been used more than other methods, is usually the preferred testing method once the boiler region has been found to have SAC present. It is important that the NDE service company be experienced and qualified to test for SAC indications, regardless of the inspection method used.

#### **Recommended Actions:**

**Inspection:** Inspection intervals for SAC are dependent on prior history. A baseline inspection for SAC should be performed if leaks have occurred at weld attachments, or if the boiler is older than about 15 years. If SAC is found, the inspection should be expanded to determine the extent of damage.

**Repairs:** Tube leaks caused by SAC damage should be confirmed by metallurgical examination. An alternative is to examine the leaking tube by RT to assist in identification of SAC. Repair of SAC damage by rewelding is not recommended because the extent of ID damage is usually unknown and not visible to the welder. Therefore, only tube replacement in the SAC affected area is recommended. Boiler OEMs have developed improved attachment designs to resist SAC; consideration should be given to use of an improved design for large and/or long-term repairs.

#### **Additional Information & References:**

BLRBAC ESP Document

OEM & Service References:

Babcock & Wilcox Plant Service Bulletin # 29

ANSI/NACE Standard RP0204-2004 Stress Corrosion Cracking (SCC) Direct Assessment Method

TAPPI: SP 05010

EPRI

## **1.2 Weld Repair of Cracks in Water Tubes**

**Description:** This guideline addresses the repairs of stress propagated defects (cracks) that have gone some percentage into the tube wall, including through wall. This procedure is limited to repairs that compromise the pressure-retaining boundary of the tube.

**Potential for Exposure:** Critical/ Non Critical, depending on the location of the crack and the potential of creating a smelt water reaction from the introduction of water into the furnace.

**Details / Causes:** Stress risers and/or corrosion generally assists cracking in boiler tubes. Cracks can propagate from the external or internal surface of a tube. The quality of fabrication, erection, and welds are also potential causes of cracking.

**Boiler areas affected:** Termination welds (fins, membrane), port openings (closure plates), port openings (composite tubes, weld overlay tubes), tube penetration location where movement of tubes are not adequately restrained (generating bank, economizer, screen tubes), structural attachment welds (buckstay, scallop plate), localized overlay weld repairs.

**Recommended Inspection:** For non destructive testing (NDT) techniques used in initial crack detection. Some inspection techniques used to assess the severity of the detected indication are, Dye Penetrant Test, Ultrasonic Inspection, Radiographic Inspection, and magnetic particle inspection.

**Recommended Actions:** Completely remove the crack with a minimum amount of grinding, perform NDT examination to ensure complete removal. Weld repair the area using approved weld procedures and verify the quality of the repair. For through wall crack repairs, consider contamination from waterside deposits when selecting an appropriate weld repair procedure (reference xxx). Through wall cracks attributed to stress assisted corrosion (SAC) should not be repaired using the guidelines listed above. To address cracks caused by SAC refer to the BLRBAC Materials and Welding Subcommittee bulletin addressing SAC.

### **Additional Information & References:**

OEM & Service References:

The AF&PA Recovery Boiler Reference Manual Volume II Maintenance and Repair Analysis: Repair Guidelines and Practices 4.5.5

NBIC RB-4480, RD-2020, Appendix K-1032

### **1.3 Repair of Pressure Boundary Materials in Tubes**

**Description:** Identification, Repairing and Inspection of pressure retaining materials in tubes.

**Potential for Exposure:** Critical

**Details / Causes:** Mechanical erosion, corrosion, impact damage, external pitting, grind marks and electrode arc-strike. The repair methodology described within this bulletin is for areas where sufficient material is present to eliminate the possibility of a blow-through with the available weld process method.

**Boiler areas affected:** Any tube within boiler

**Recommended inspection:** Perform visual inspection to identify areas where wall thickness has been compromised followed by thorough UT of areas of concern.

- PT should be used when corrosion resistant coatings are present to determine exposure of pressure retaining materials. UT of these exposed areas to quantify wall thickness.
- Routine UT mapping of boiler tubes per BLRBAC guidelines.

**Recommended Actions:** Compare thickness data versus historical corrosion data to timeline for reaching minimal wall thickness. Several options exist for managing this challenge after historical data and next possible inspection date is considered:

1. If corrosion is not severe, it is possible to make no repair and revisit during next inspection date.
2. Make localized repairs using approved weld build-up procedures (2.3) Repair of Pressure Boundary Materials in Tubes
3. Replace thinning tube with new tube

Perform post-repair visual inspection to identify general poor welding practices.

Further testing may be required to determine root-cause failure mechanism which may require sampling and destructive testing.

#### **Additional Information & References:**

TAPPI:

OEM & Service References:

NBIC

### **1.4 Repair of Corrosion Resistant Weld Overlay Applications on Tubes**

**Description:** Identification, Repairing and Inspection of existing corrosion resistant weld overlay materials

**Potential for Exposure:** Non-critical, but if not corrected could lead to critical potential for exposure. The repair methodology described within this bulletin is for localized thinning of overlay material that has not yet penetrated to pressure retaining material.

**Details / Causes:** Mechanical erosion, localized corrosion and electrode arc-strike

**Boiler areas affected:** Any tube within boiler where corrosion resistant weld overlay has been applied; in general, but not limited to, waterwall and superheat tubes.

**Recommended inspection:** Visual inspection of applied weld overlay to identify areas where weld thickness has been compromised (weld bead ripples versus smoothing of weld overlay); followed by thorough UT of areas of concern.

- If tube material is removed for replacement, it is recommended to perform Destructive testing of samples to determine mechanism as chosen material may not be adequate for environment.

**Recommended Actions:** Compare thickness data versus historical corrosion data to timeline for reaching minimal wall thickness. Several options exist for managing this challenge after historical data and next possible inspection date is considered:

1. If corrosion is not severe, it is possible to make no repair and revisit during next inspection date.
2. Make localized repairs using approved weld repair procedures
3. Replace tubing with appropriate corrosion protection.

Perform post-repair visual inspection to identify general poor welding practices.

#### **Additional Information & References:**

TAPPI:

OEM & Service References:

The AF&PA Recovery Boiler Reference Manual Volume II Maintenance and Repair Analysis: Repair Guidelines and Practices 4.5.5.4

NBIC

### **1.5 Repair of Composite Materials on Tubes**

**Description:** Identification, Repairing and Inspection of existing corrosion resistant composite materials

**Potential for Exposure:** Non-critical, but if not corrected could lead to critical potential for exposure. The repair methodology described within this bulletin is for localized thinning of composite material that has not yet penetrated to pressure retaining material.

**Details / Causes:** Mechanical erosion, localized corrosion and electrode arc-strike

**Boiler areas affected:** Any tube within boiler where composite tubes have been installed; in general, but not limited to waterwall and superheat tubes.

**Recommended inspection:** Perform visual inspection of composite tube to identify areas where alloy thickness has been compromised followed by thorough UT of areas of concern.

- If tube material is removed for replacement, it is recommended to perform Destructive testing of samples to determine mechanism as chosen material may not be adequate for environment.

**Recommended Actions:** Compare thickness versus historical corrosion data to timeline for reaching minimal wall thickness. Several options exist for managing this challenge after historical data and next possible inspection date is considered:

1. If corrosion is not severe, it is possible to make no repair and revisit during next inspection date.
2. Make localized repairs using approved weld repair procedures
3. Replace tubing with appropriate corrosion protection.

Perform post-repair visual inspection to identify general poor welding practices.

**Additional Information & References: (Section to be completed)**

TAPPI:

OEM & Service References:

NBIC

**SECTION 2 – WELDING GUIDELINES & PROCEDURES SECTION**

**2.1 Replacing Hand Hole Caps (Weld in Style)**

**2.1.0 General**

Some older recovery boilers utilize new and old style hand hole caps of varying size and metallurgy. It is common that new style hand hole caps are installed during rebuilds. There are instances when OEM’s suggested an alloy upgrade of all caps to avoid complication. Care must be taken when removing alloy caps and returning to carbon steel. Best practice is to consult the OEM or other competent technical advisor.

**2.1.1 Hand Hole Cap Metallurgy**

Hand hole caps are available in carbon steel (SA-181-70) or 2 ¼ Cr-1 Mo (SA-182 F22 CL3). The material identification for a typical B & W hand hole cap is stamped on the bottom (rounded) surface. Newer style B & W hand hole caps fabricated with carbon steel are stamped as 80MM, SM17, SM16, or SM70SI; and caps fabricated with 2 ¼ Cr-1 Mo are stamped as 78MM, AM17, AM16, or AM70SI. The old style B & W hand hole caps sizes are 3-1/4" and 4-1/2". There are also “Master” caps, and “Standard” which the Owner should have new spares in stock.

Typical Hand Hole Material – Filler Metals selection

<b>ELECTRODE SELECTION BASED ON MATERIAL</b>			
<b>Hand Hole Cap Material</b>	<b>Header Material</b>		
	Carbon Steel (P1 Material)	1 ¼ Cr-1/2 Mo (P4 Material)	2 ¼ Cr-1 Mo (P5A Material)
Carbon Steel	E7015-A1 E7016-A1 E7018-A1	Unacceptable combination between header and hand hole cap	Unacceptable combination between header and hand hole cap
2 ¼ Cr-1 Mo	E7015-A1 E7016-A1 E7018-A1	E8016-B2 E8018-B2	E9015-B3 E9016-B3 E9018-B3

<b>PREHEAT AND INTER-PASS TEMPERATURES</b>
Preheat – Refer to WPS and code of construction Inter-pass - Refer to WPS and code of construction

### **2.1.2 Reusing hand hole caps:**

It is recommended to replace all weld-in hand hole caps removed with a new cap. However, in the event a new cap is unavailable, re-using an old hand hole cap is acceptable if the cap can be adequately cleaned up; any removed cap material be replaced with weld metal and liquid dye penetrant testing performed.

### **2.1.3 General Good Practice Items:**

- a. The Contractor and Owner should agree on hand hole cap removal and installation requirements. It is advisable to have the Owner's representative and the Contractor both mark the specific hand hole caps that are to be removed, and verify there are the correct replacement caps in hand, before removing any caps.
- b. Owner's representative should monitor the hand hole cap removal and installation. (See suggested welder guidelines and welding traveler).
- c. NDE work should be performed by technicians qualified according to SNT TC-1A for the test work performed. A minimum of Level II technician is required to interpret results.
- d. Weld acceptance criteria, including VT, is to be in accordance with ASME Section I.
- e. All welders who will be performing the cap removal and installation process should receive training on the procedure and QC requirements.
- f. When a large amount of caps are to be replaced such as for a boiler cleaning, it is best practice to set up a mock assembly for testing welder proficiency.
- g. If there are alloy caps in the superheater headers, and carbon steel in the balance of headers, it is good practice to paint code both the header and the caps.
- h. Account for all the removed caps (caps have been left in the headers, just out of sight).
- i. Each header should be inspected internally by the owner's representative prior to closure.

### **2.1.4 Hand Hole Cap Removal Procedure**

- a. Only the seal weld is to be removed. The seal weld may be removed by arc gouging or grinding. Care needs to be taken so that excessive metal is not removed from the header and the header seat is not damaged.
- b. Remove cap from the header. Account for all removed caps.
- c. After cap removal, lightly prepare the header opening area to clean it up for inspection. Grind the header surfaces for at least 1/2" on each side of the welding area to remove any pitting, rusting or other surface oxides. Thoroughly clean the header seat and bore as well as all welding surfaces of weld spatter, oil or grease, debris, oxides, paint or other substances. Use a cleaning solvent to remove grease and oil if present.

- d. Liquid dye penetrant examination should be performed on the header opening.
- e. Determine whether header repairs are required. (Shoulder must be square, hole diameter within tolerances, header thickness in seat area within tolerance, no linear indications in parent header metal, no visual defects).
- f. Remove any defects and perform a dye penetrant examination to assure no defects remain.

### **2.1.5 Header Repair Procedure**

- a. Header build up procedure is to be established by the contractor and approved by Owner. Weld inspection QC should verify proper weld metal, procedures, preheat and weld interpass temperatures. No repair to the header should be performed while welding in the hand hole cap, it should be done before installing the cap.
- b. Clean the surface of all grease, oil and dirt.
- c. Ensure preheat has normalized through the header per WPS and code of construction.
- d. Build up the header opening and grind, or machine the surface to the original hole configuration. Verify that the header edge is square and is of proper thickness.
- e. Final prepared surface to be VT, PT or MT examined, prior to welding to verify sound repairs and no porosity, cracks, etc.
- f. Perform internal inspection of header before closure.

### **2.1.6 Hand Hole Cap Installation**

- a. Do not “prick punch” the cap seating surface, on a B&W style cap. The CE Style caps need this for shrinkage allowance of the weld metal.
- b. Position the cap in the hole oriented per the drawings. The cap should be centered in the hand hole. Verify dimensions 90 degrees apart. There should be no excessive gap between the header and cap. Verify that cap dimension is correct, and check fit up gap.
- c. Pull a non CE Style cap up into the socket using a strongback, this helps to hold the hot hand hole cap and can eliminate the need for tack welds. Tack welds are best avoided, if possible, but if a cap pulling fixture is not available, place minimum 1” tacks, and feather the start and stop of each and VT examine, do not reduce the preheat if using tacks.
- d. For CE Style caps, “prick punch” the cap seating surface using a center punch or chisel to apply several punch marks to the end of the mating face of the cap. This is to upset the mating faces and allow for shrinkage of the weld.
- e. For other cap styles, refer to manufacturers guidelines for installation procedures.
- f. Apply a preheat (refer to code to determine correct temperature for different metallurgies of cap and header) to the header and cap. Use temperature indicating crayons to confirm temperature

- is within parameter. The greater of 15 minutes or 15 minutes per inch of thickness should be allowed for temperatures to normalize. Check the header temperature approximately 1/2” and 3” away from the weld area. Confirm the cap for temperature at the same time.
- g. Once temperature has been verified, hold and maintain the temperature, with periodic temperature verification throughout completion of the welding and NDE QC inspecting.
  - h. Root pass requires a VT inspection. Welder is to clean up the weld root pass of all slag for inspection. Maintaining the interpass and preheat temperature are vital.
  - i. Make a 3/8” throat fillet weld (1/2” or less leg) per specifications (refer to drawings in this guideline). Weld in excess of 3/8” throat will require PWHT as per ASME I-PW-39, or Alternate Rules to PWHT per NBIC.
  - j. The weld starts and stops are to provide continuous overlap of the previous weld pass (a staggered bead).
  - k. The root pass should provide uniform weld penetration into both the cap and header.
  - l. The completed weld is to be cleaned for inspection.
  - m. NDE final examination should include VT (including weld dimension) and MT if temperature is over 200°F, or PT or WFMT if cooled off.
  - n. Insulate the cap and surrounding area for slow cooling after final welding.

**2.1.7 Handhole Caps Welding Guidelines – Removal Sequence & Header Repairs**

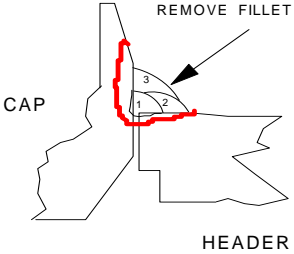
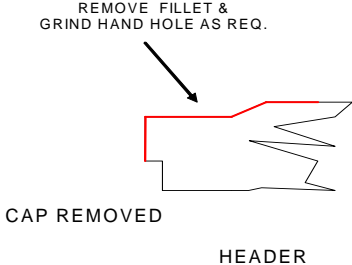
<p><b>STEP 1</b></p> <p>CAP REMOVAL</p>		<p>Remove the header hand - hole cap seal weld by arc gouging or grinding.</p> <p>Take care to remove only the old weld. Watch closely while gouging for any cracks.</p> <p>If there is any indication of cracks forming during the gouging process then preheat the header to 200° F minimum before further gouging.</p>
<p><b>STEP 2</b></p> <p>CLEAN / GRIND / DYE – PENETRANT</p>		<p>Clean the header hand hole prep area by grinding; if cracks are present; use a rotary burr, to avoid “pushing, or chasing the crack”.</p> <p>Check fit up with the replacement cap.</p> <p>Visually inspect for cracking or porosity. Porosity indicates old weld remains.</p> <p>Perform MT or PT on weld prep surface area.</p>

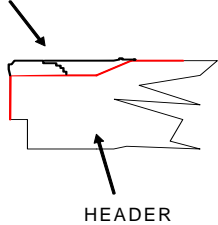
<p><b>STEP 3</b></p> <p>HEADER WELD REPAIRS</p>	<p>REMOVE EXCESS WELD BY GRINDING HAND HOLE AREA.</p> 	<p>PREHEAT. (may vary with alloy, follow WPS).</p> <p>Make any necessary weld repairs around the hand hole opening. Depth of repair may involve PWHT or NBIC Alternate Rules to PWHT.</p> <p>The weld repairs should make a smooth base for the final hand hole cap fillet weld.</p>
<p><b>STEP 4</b></p> <p>FINAL PT or MT BEFORE CAP INSTALL.</p>	<p align="center">OLD CAP REMOVED, WELD REPAIRS MADE, &amp; CALL FOR INSPECTION.</p>	<p>NDE examination should include VT and MT if temperature is over 200°F, or PT or WFMT if cooled off.</p>

**2.1.8 Handhole Caps Welding Guidelines – Installation Sequence**

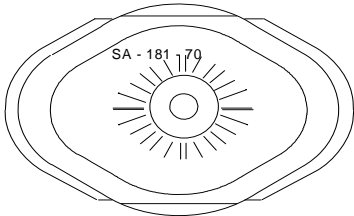
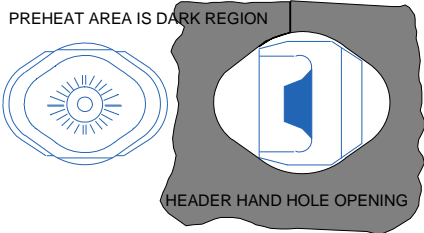
<p><b>STEP 5</b></p> <p>CHECK CAP FOR PROPER MARKING.</p>	<p>GRADE 70, CARBON STEEL FORGING</p> 	<p>Examine the handhole cap to assure that it is stamped with the material designation (e.g., SA 181–70 or SA 181–60). Manufacturer markings must be verified to identify code material. Check for appropriate welding procedure.</p> <p>Clean the area to be welded using a clean wire brush and/or light abrasive wheel.</p>
<p><b>STEP 6</b></p> <p>CAP PREP</p>		<p>For B&amp; W Style Caps go to next step. For C.E. Style Caps: Using a center punch or chisel – apply several punch marks to the end of the mating face of the cap – this is to upset the mating faces and allow for shrinkage of the weld, which will pull the cap into the header.</p>
<p><b>STEP 7</b></p> <p>INSERT CAP AND PREHEAT</p>	<p>PREHEAT AREA IS DARK REGION</p> 	<p>Insert the cap through the counter bored header handhole. The cap must be passed through the handhole and then rotated 90° so you can see the center boss thread.</p> <p>Use the threaded boss to center the cap during welding. Preheat cap and header (may vary with material; follow WPS and code of construction).</p>

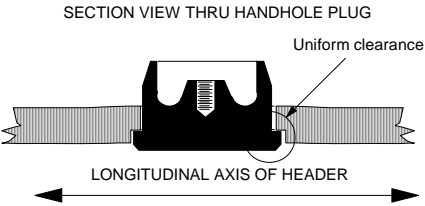
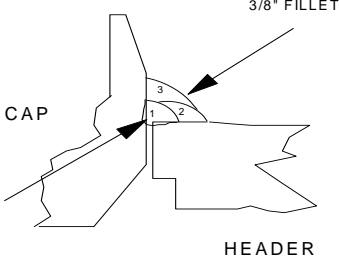
<p><b>STEP 8</b></p> <p>TACK WELD, FEATHER TACKS (CE Style cap)</p>		<p>Welding may be performed with SMAW (STICK) OR GTAW (TIG). DO NOT EXCEED MAXIMUM INTERPASS TEMPERATURE; follow WPS and code of construction.</p> <p>If a welding fixture is used to pull the cap into the seat, omit the tacks; if not, apply 2 tack welds about 1” long (not a button weld) on each side of the cap.</p> <p>Clean &amp; “feather grind” each tack such that no slag remains from the tack welding. A rotary burr works well for feathering.</p> <p>The weld root shall be made so as to tie-in the header and cap with no greater than 1/32” undercut, and no coldlap, or visible porosity. Weld out the root pass on one half of the cap. Complete the root pass and remove any slag.</p>
<p><b>STEP 9</b></p> <p>WELD &amp; LIMIT INTERPASS TEMP.</p>		<p>DO NOT EXCEED MAXIMUM INTERPASS TEMPERATURE; follow WPS and code of construction.</p> <p>The weld must have an effective throat of less than 3/8” which can be performed with a 3 pass or multi pass joint with a leg of less than 1/2”.</p> <p>A 3-pass fillet is shown.</p> <p>Run bead number 2 with its start point staggered inside of and against the header side of the root pass. Use a staggered start / stop weld bead sequence, grinding the starts and the stops completely off to sound metal, to allow consistent weld height, and removal of any start porosity.</p> <p>Complete the weld with bead number 3, placed so as to tie the passes 1 &amp; 2 to the cap itself. This bead may be a stringer cover or a slightly weaved cover pass.</p> <p>For multipass welds greater than 3 pass, (refer to section 2.1.8 below to see additional detail 6 pass weld showing 1/2” leg fillet profile).</p>

<p><b>STEP 10</b> FINAL INSP</p>		<p>Perform final VT (visual inspection) and assure a maximum 3/8" EFFECTIVE THROAT fillet weld. A fillet weld with a 1/2" leg will typically have a 3/8" throat. Final MT if temperature is over 200°F, or PT or WFMT if cooled off. Fillet welds with a throat over 3/8" require PWHT.</p>
--------------------------------------	---	---

### 2.1.9 Detail of 1/2" Leg Fillet Weld

When necessary or requested, a multi pass weld with 6 passes is common, and it still has a throat of 3/8". This is shown as an option to the standard 3-pass fillet weld, as illustrated on the Handhole Caps Removal & Welding Guidelines installation sequence ~ handhole - cap.

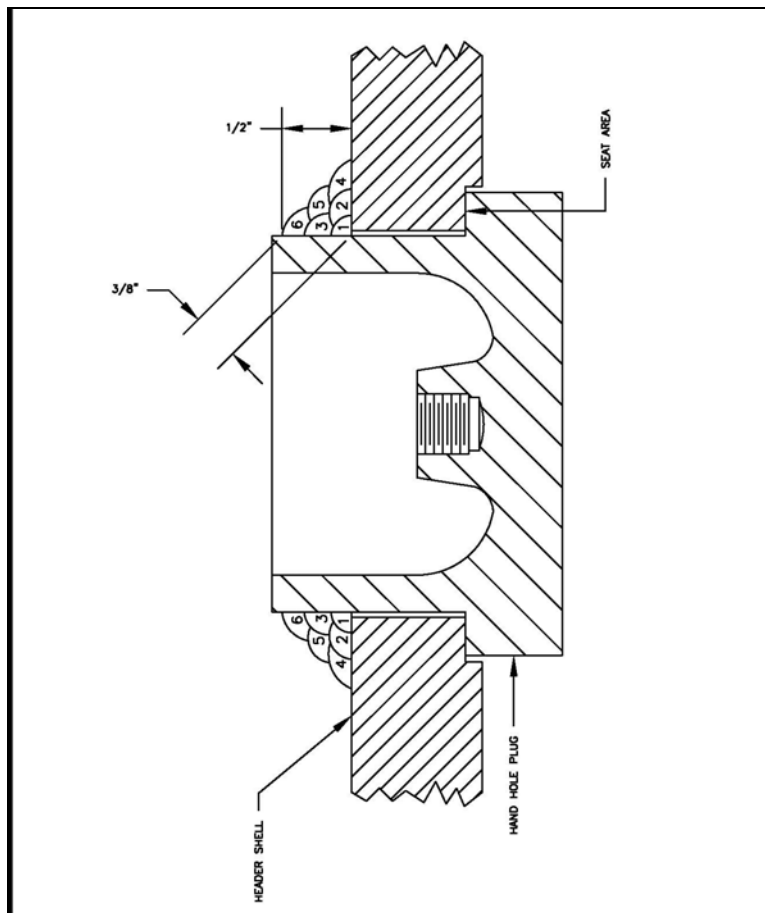

**2.1.10 Weld Traveler**

Unit I.D. & Pressure Part:	
Welding Procedure	
Header & Cap(s):	

**H = Hold Point**, No work to proceed beyond the task item until the hold item is checked, and signed off.  
**V = Verification**, Work may proceed beyond the task, but it shall be noted as being checked, by leadman, foreman, or supervisor on shift, so as not to hold up the work. There will be a final sign off of this “V” by owners’ representative.

STEP	ITEM & DESCRIPTION Hand Hole Cap Installation	HOLD	Contractor Sign-Date	HOLD	CUSTOMER Sign - Date	HOLD	A.I. Sign-Date
1	REMOVAL OF EXISTING HANDHOLE CAP						
2	CLEAN-UP HEADER AND SEAT						
3	NDE-EXAMINATION OF CLEANED HEADER – PT/MT						
4	WELD BUILD UP OF HEADER (IF REQUIRED) Preheat Monitored@ _____ °F						
5	NDE - EXAMINATION OF HEADER BUILD UP – PT/MT <i>(may be waived for final PT)</i>						
6	INTERNAL HEADER INSPECTION <i>(prior to closure)</i>						
7	FIT –UP OF NEW CAP – ORIENTATION & TACKING Review weld bead sequence						
8	PREHEAT – MONITORED @ _____ °F						
9	ROOT PASS						
10	WELDING OUT						
11	INSPECTION – COMPLETED WELD – FINAL VISUAL / PT, WFMT or MT Dry						

References:

1. Master Hand Hole (MHH) Plug Welding Recommendations, Babcock & Wilcox Plant Service Bulletin # 53, Babcock .com
2. ALSTOM's AComPower's Quarterly Newsletter "Tidbits", Issue #107, October - December 2002

## **2.2 Weld Repair of Small Holes / Cracks in Superheater Tubes**

### **2.2.1 Introduction**

- a. This procedure applies once the need for a repair has been determined. Refer to Forward and Associated Technical Bulletin for guidelines to determine need for repair. Jurisdictional requirements should be considered and followed.
- b. Small holes/cracks in superheater tubes may be weld repaired. The tubes being steam-filled, the internal surfaces should be free of deposits; therefore, there is little risk of weld contamination.
- c. Types of holes/cracks in tubes that may be repaired if the criteria in 2.0 are met
- d. Crack originating on the external surface at an attachment weld
- e. Torch cut occurring during repairs
- f. Excessive grinding during repairs
- g. Deliberate grinding for known purposes, such as draining of superheater tubes
- h. Mechanical damage from sharp tools driven into tubes
- i. Attachment weld pulled from tube, which pulls out tube metal
- j. Arc strikes that are severe enough to blow a hole in a tube
- k. If the cause is internal corrosion pitting or fatigue, the tube section must be replaced.

### **2.2.2 Evaluation**

- a. Criteria for weld repair of small holes/cracks in superheater tubes
- b. After preparation for welding the excavation does not exceed:
- c. 1/8" in width at the root
- d. 25% of the tube circumference for circumferential length and 2" for longitudinal length (the limit on circumferential length is due to stresses in welds that do not run the entire circumference. These stresses are not a problem in longitudinal welds. The longitudinal length limit is intended to restrict the length of longitudinal repairs in lieu of sectioning).
- e. Root cause is known, i.e., torch cut mechanical damage, etc.
- f. Assuming there are no other thin areas, tube thickness adjacent to the area to be repaired is not less than Code minimum.
- g. There are no branched cracks running from a crack intended to be repaired, as determined by MT or PT examination
- h. The tube area adjacent to the repair area is free of distortion inward or outward from the normal plane of the tube surface

### **2.2.3 Materials**

- a. Welding materials shall be qualified for use by the Welding Procedure Specification (WPS).

### **2.2.4 Procedure**

#### **2.2.4.a Weld repair procedure for a torch cut, grinder cut, sharp tool damage or severe arc strike**

- a. Measure the hole
- b. Take thickness measurements immediately adjacent to the hole and compare the measurements to minimum allowable wall thickness
- c. Remove all contaminants at the edge of the hole and bevel the edges to an approximate 37 ½ degree angle as for a butt weld
- d. Make the repair per approved welding procedure.
- e. Ensure interpass temperature for the chrome-moly material is not exceeded.
- f. The root pass, and preferably the hot pass, should be made by the GTAW process to assure a full penetration weld if the repair is through-wall.

#### **2.2.4.b Weld repair procedure for cracks**

- a. Determine the length of the crack by MT or PT examination. Ensure that there are no branched cracks.
- b. Take UT thickness measurements adjacent to the crack to ensure Code minimum thickness
- c. If a crack adjacent to a tie weld or a spacer type tie (dovetail, “D” link or hinge pin sleeve) is to be repaired, remove the tie weld or spacer tie. When a spacer tie is removed, check the area adjacent to the weld repair with a copper sulfate solution to identify any remaining stainless or alloy material. All stainless or alloy material must be removed prior to making the weld repair.
- d. Grind out the crack. Check for complete removal by MT or PT examination. The crack must be completely removed.
- e. Make the repair per approved welding procedure.
- f. Ensure interpass temperature for the chrome-moly is not exceeded.
- g. The root pass, and preferably the hot pass, should be made by the GTAW process to assure a full penetration weld if the repair is through-wall.
- h. Reinstall the tie 2”, +/- 0.5”, above or below the weld repair.

### **2.2.5 Acceptance**

- a. Traveler documented at the discretion of the owner and repair contractor.

- b. Final inspection, testing, and documentation of repairs
- c. Examine the finished weld, visually and by MT or PT.
- d. Documentation of hole/crack repairs in superheater tubes is at the discretion of the plant, however, a Report of Welded Repair may be required by jurisdictional requirements. If the repair is required because of an unscheduled outage, the repair should be documented in a failure report.
- e. Information concerning the repair should be recorded as outlined below.
  - i. Date of repair
  - ii. Platen number, tube number, row number and elevation should be recorded.
  - iii. Cause of the hole
  - iv. Size of the hole
  - v. Person authorizing the repair
  - vi. Welding inspector accepting the repair

### **2.2.6 Reference**

The AF&PA Recovery Boiler Reference Manual Volume II Maintenance and Repair Analysis: Repair Guidelines and Practices 3.7.1.112

## **2.3 Repair of Pressure Boundary Materials in Tubes**

### **2.3.1 Introduction**

This procedure applies once the need for a repair has been determined. Refer to the General Welding Forward and Associated Technical Bulletin for guidelines to determine need for repair. Jurisdictional requirements should be considered and followed.

Erosion or corrosion of boiler tubes may occur over large areas or may be confined to relatively small spots. The repair options vary according to the severity of the metal loss, the area of coverage, the type boiler, the location in the boiler, etc. Weld buildup may be used for repair of eroded, corroded, or mechanically damaged tubes when the defects do not exceed those listed under Special Restriction in this document.

### **2.3.2 Evaluation**

Ultrasonic thickness measurement or other nondestructive techniques shall be used to map the extent of thinning and assess the size of the area to repair. Visual examination shall also be conducted to look for any evidence of cracking or bulging of tubes. It is recommended that the last water wall tube sample data be reviewed to determine if water side deposits is a contributing factor to the thinning observed. Also, if there are high amounts of copper present in the waterside deposits, a problem with tube metallurgy (embrittlement) could be caused during welding.

### **2.3.3 Materials Selection**

The area can be repaired using material conforming to the original code of construction including the material specification requirements.

### **2.3.4 Special Restrictions**

This procedure should only be used on recovery boilers only when the following criteria are met:

- The remaining thickness of the pressure boundary base material is:
  - Sufficient to prevent burn through dependant upon welding process
  - If below minimum wall thickness additional considerations should be applied
    - Size of thinned area
    - Location in unit
    - Local jurisdictional requirements
    - Remaining wall thickness
    - Other applicable codes and regulations
- When the tube surface is free of defects such as bulges or cracks
- The surface must be free of material that could be detrimental to welding. This normally requires grit blasting to a white metal finish, or localized grinding.

### **2.3.5 Welding**

During the welding process, there should be a welding inspector onsite to witness the entire repair as it is being performed.

#### **Welding Technique**

Welding current that will produce complete-fusion without burn through. Fill the repair area with a series of stringer beads, except that weaving is permitted in the vertical position to a maximum width of about 2-1/2 times the electrode diameter. Deposit thin beads to minimize melt through.

More than one layer is permitted if the first layer does not completely fill the wasted area.

#### **Cleaning and Removing Defects**

All unfused weld metal, voids, slag, weld splatter, and irregularities should be removed from each weld bead before depositing a succeeding weld bead. If burn through or melt through is suspected, the tube section should be replaced or examined radiographically or ultrasonically (see final inspection).

#### **Weld Finish**

The surface of the completed weld shall be ground free of weld surface irregularities. The edge of the weld shall merge smoothly into the surface of the tube, but the tube should not be ground under-gauge. A slight crown or reinforcement up to 1/16" may remain and shall not exceed the width of the wasted area by more than 3/16 of an inch.

### **2.3.6 Final Inspection**

Close visual examination by a welding inspector is required for all welded repairs.

The integrity of the repair shall be verified by one of the following methods for pressure boundary repairs where a failure is not likely to allow water to enter the furnace:

- Magnetic particle testing (MT)
- dye penetrant examination (PT)
- hydrostatic test

For repairs where failure is likely to allow water to enter the furnace MT or PT shall be performed prior to a hydrostatic test.

#### **Hydrostatic Testing**

The hydrostatic test pressure shall be adequate to verify the integrity of the repair.

### **2.3.7 Documentation**

The location, extent, filler materials and base material shall be documented and maintained for future reference.

### **2.3.8 References**

ASME PCC-2 – 2006 Article 3.4

**2.4 Corrosion Resistant Weld Overlay Applications on Tubes (Future)**

## **SECTION 3 - MATERIALS**

### **GENERAL MATERIALS FORWARD**

Recovery boiler operation at higher pressures, temperatures and liquor solids has resulted in increased corrosion and deterioration of furnace tubes and boiler components. Examples of significant new materials introductions in the past 30 years to resist recovery boiler corrosion are composite and chromized tubes, weld overlaid tubes and different thermal metal spray coatings. Likewise, new refractories and nonmetals have been introduced in efforts to protect fireside components, and for application in specialized use areas such as smelt spouts. Duplex stainless steels have been more recently used to provide resistance to stress corrosion cracking of tanks and vessels.

The BLRBAC Materials and Welding Subcommittee provides a format to review areas where materials applications have been successful, as well as where there have been failures. This is done using the combined expertise of the subcommittee membership – personnel representing OEM's, owner-users, repair contractors, insurance and consultants.

The subcommittee has also initiated surveys to evaluate current materials practices, and the relative success of these practices. The objectives of the surveys are to assist the subcommittee in defining damage mechanisms, causes, operating issues and materials solutions. Examples have been surveys on materials for black liquor nozzles, smelt spouts and smelt spout steam shatter jets.

The Materials and Welding Subcommittee welcomes comments and suggestions for new materials' applications, or ideas where materials may be better used for solving old and arising recovery boiler problems.

### **3.1 Materials Surveys Results:**

#### **3.1.1 Black Liquor Nozzle Wastage**

#### **3.1.2 Scope**

A survey was conducted to identify the common causes and solutions to corrosion of black liquor nozzles and piping.

#### **3.1.3 Corrosion Characteristics**

Wastage of black liquor nozzles and piping have been reported to have the following characteristics:

- Corrosion at the top of the 45° elbow before the nozzle
- Corrosion of the nozzle body
- Corrosion of the splash plate

#### **3.1.4 Causes of Corrosion**

The following were reported to be suspected causes of corrosion of black liquor nozzles and piping:

- Extension of nozzle too far into the furnace
- Plugging (scaling) of piping and subsequent overheating
- Small liquor gun port size and subsequent minimal cooling air flow
- Insufficient port cleaning and subsequently reduced cooling air flow

### **3.1.5 Operating Issues**

The following operating issues were found to be directly related to the occurrence of liquor nozzle and piping corrosion:

- Excessive carryover and the adoption of suspension firing caused smelt to flow down the furnace walls and onto the liquor nozzles.
- Increasing the black liquor solids from 68% to 76% resulted in liquor nozzle corrosion.

### **3.1.6 Mechanical Solutions**

- Retract liquor guns closer to the furnace wall
- Rod/clean liquor gun ports more frequently
- Position liquor gun at the center of the port to achieve even air flow around gun
- Increase secondary air flow

### **3.1.7 Materials Solutions**

The following materials were reported to provide satisfactory life of liquor nozzles and piping in order of decreasing effectiveness:

- Allstel (55 % Cr / 45 % Ni)
- 50% Cr/ 50% Ni
- Stellite
- Duplex (example 2205)
- Inconel
- Type 316 stainless steel
- Type 304 stainless steel

Black liquor nozzle life was reported to range from two months to 12 months using stainless steel. The life of stainless steel black liquor piping was reported to be in the range of three months to two years.

### **3.2 Smelt Spout Materials Survey**

#### **3.2.1 Scope**

A survey was conducted to identify common materials and operating solutions for addressing corrosion of carbon steel smelt spouts. The specific form of corrosion being addressed involves wastage of the spout at the smelt exit end in the vicinity of the steam shatter jets.

#### **3.2.2 Corrosion Characteristics**

The smelt spout wastage is characterized as affecting as little as the lower six inches of the smelt spout trough to as much as 75% of the trough length. Corrosion can also affect the discharge lip of the spout, the bottom of the outer trough, end plate and any cooling piping located in the vicinity of the smelt exit. The corrosion does not necessarily affect all smelt spouts on the boiler to the same degree.



#### **3.2.3 Causes of Corrosion**

The following were cited as possible causes of corrosion of smelt spouts at the smelt exit end:

- Low cooling water temperature
- Condensation of vapors within the smelt spout enclosure
- High dissolving tank level resulting in excessive vapor formation
- Inadequate venting through the dissolving tank vent stack
- Splashing due to excessive smelt shattering
- Misalignment of the smelt shatter jets and splashing on the spout

- Splashing of weak wash onto the spouts

### **3.2.4 Materials Solution – Weld Metal Overlay**

The following materials applied in the form of weld overlay were reported to be successful in resisting corrosion and provide a minimum service life of twelve months.

- Austenitic Alloy Steel (18% Cr)
- Austenitic Alloy Steel (25% Cr)
- Inconel 625 (8 % Mo)
- Inconel 622 (12 % Mo)
- Hastelloy C276
- Alloy 72 (40 % Cr)

Weld overlay should be done from 3:00 to 9:00 positions on the spout to cover the tide line; overlay can be done over one foot at the discharge tip of the spout, and should cover the end plate, and wrap around to cover the bottom one inch of the outer trough. The transition inside the trough should be ground to provide a smooth transition of the different materials, or it can be applied the entire length of the spout trough.

The following material(s) applied in the form of weld overlay were reported to perform satisfactorily in some cases but not in others:

- Hastelloy C

The following material(s) applied in the form of weld overlay were reported to perform poorly:

- Inconel 600

Erosion at the transition from an eddy effect can cause early failure if a smooth transition is not prepared.

### **3.2.5 Materials Solutions – Miscellaneous Forms of Corrosion Protection**

The following forms of corrosion protection were reported to perform satisfactorily in some cases but not in others:

- Thermal spray coating (45CT)
- Chromizing

## **3.3 Smelt Spout Steam Shatter Jet Materials Survey**

### **3.3.1 Scope**

A survey was conducted to identify materials solutions for wastage of smelt spout shatter jets and associated piping/assemblies.

### **3.3.2 Corrosion Characteristics**

Wastage of smelt spout shatter jets and associated piping/assemblies have been reported to have the following characteristics:

- Wear of steam holes
- Wastage on top of shatter jet assembly
- Wastage of steam feed piping

### **3.3.3 Causes of Corrosion**

The following were reported to be suspected causes of corrosion of steam shatter jets and associated piping/assemblies:

- Erosion of steam holes due to high velocity
- Smelt corrosion
- Insufficient cooling due to smelt pluggage

The survey showed that steam shattering systems are operated in the range of 60 – 165 psi and 310 – 400F. There was no relationship between the occurrence of corrosion and the pressure or temperature of the shattering steam.

### **3.3.4 Materials Solutions**

Type 304L stainless steel was reported to be effective in minimizing corrosion of steam shatter jets and associated piping/assemblies. Type 304L stainless steel was reported to perform satisfactorily when used as a monolithic and as a weld overlay over carbon steel.

316 can be used in nozzle designs to preserve attachment welds.

**3.4 Materials – Miscellaneous (Future)**

**SECTION 4 – TEMPORARY REPAIRS (Future)**

## **SECTION 5 – REFERENCE SECTION**

### **5.1 OEM & Service Providers**

1. Babcock and Wilcox
2. Alstom Power
3. Southeastern Mechanical Services
4. George Bodman, Inc.

### **5.2 Technical Sources:**

AF&PA, API, ASME, ASNT, TAPPI, BLRBAC, NBIC, NACE,

**APPENDIX A DOCUMENT REVISION HISTORY**

There is no revision history. This is the first publication of this document.